

QTY	PART NUMBER	DESCRIPTION
32	1-A022	3/8-24 FLANGE NUT
32	1-A205	1" X 3/8-24 FLANGE BOLT
16	1-A239	1 1/2" X 3/4-10 BOLT
4	AT-BCE-06	L BRACKET
2	AT-BCE-08	END CONNECT TUBE
2	AT-BCE-W01	BASE FRAME
4	AT-BCE-W02	MOUNTING SUPPORT
4	AT-BCE-W03	W BRACKET LEG
1	AT-BCE-W04	CENTER CONNECT SLEEVE
2	W-C8X2P-BK-TWIRL	8X2 CASTER W/BREAK
2	W-C8X2P-TWIRL	8X2 CASTER

# AutoTwirler®

675 N 600 W STE 2, LOGAN UTAH, 84321

email: [info@autotwirler.com](mailto:info@autotwirler.com) website: [www.autotwirler.com](http://www.autotwirler.com)

3/23/15

## AUTO TWIRLER ELITE BODY CART

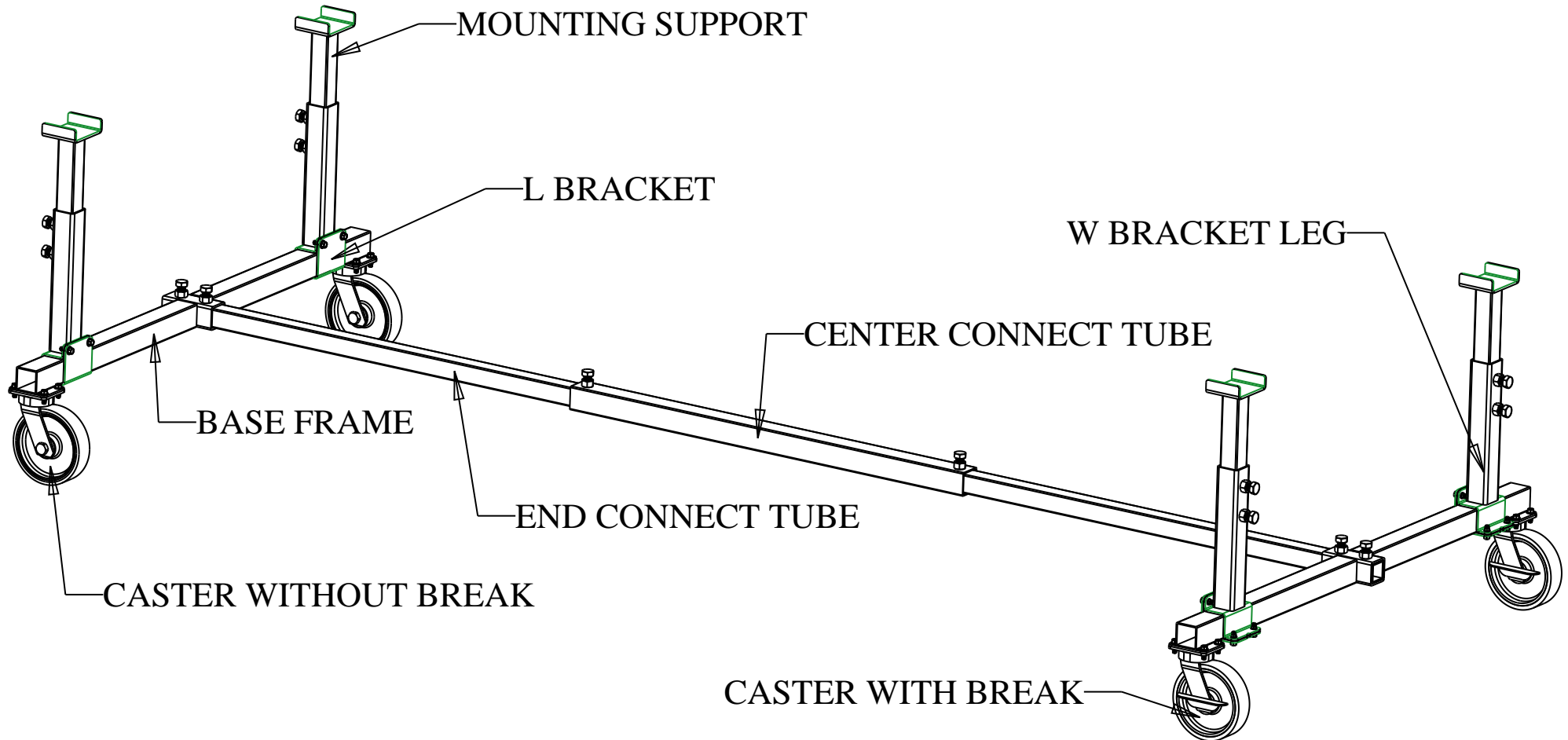

# Assembly Instructions

**\*\*ALL BOLTS SHOULD BE CHECKED, EVERY TIME BEFORE PUTTING ANY WEIGHT ON THE CART \*\***

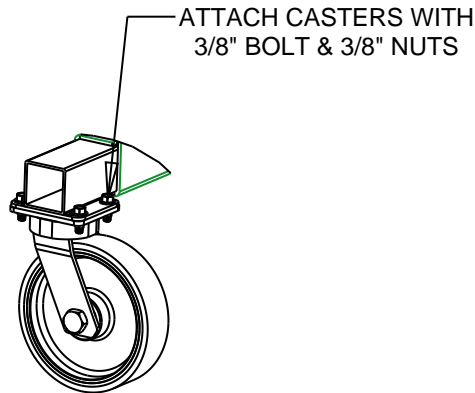

- 1.) Assemble the wheels by attaching them to the Base Frame with the 3/8" bolt and nuts.
- 2.) Insert the End Connect Tube into the Base Frame on both sides. Then slide both End Connect Tubes into the Center Connect Tube, and snug all adjustment bolts.
- 3.) Make sure the Mounting Support is inside the W Bracket Leg and bolts are snug. Then attach the W Bracket Leg to the Base Frame using the L Bracket and the 3/8" bolt & nuts.
- 4.) Adjustment is made by loosening the adjustment bolts, and sliding adjustable components in the desired direction. When adjusting, make certain both adjustment bolts still make contact with the connect tube and L & W brackets are secure.

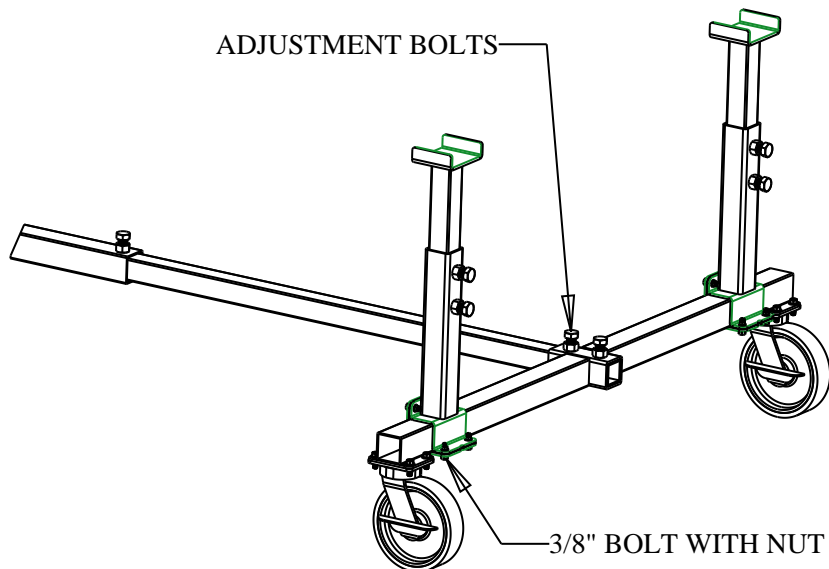

NOTE: The 3,000 lb weight rating pertains to the 8" polyurethane on cast-iron wheels shown. If the 10" solid rubber wheels are ordered, the weight rating is reduced to 2,000 lb with evenweight distribution.